



Instruction Manual for Oil-Catch Tank Kit (Cylinder type)

Item No. : 07 05 0007 (For Stock Clutch)
: 07 05 0008 (For Special Clutch)
Fits : Monkey (FI)
Frame Nos : AB27-1900001 ~

- Thank you for purchasing one of our TAKEGAWA-made products. Please strictly follow the following instructions in installing and using the kit.
- Before installing the kit, please be sure to check the kit contents. Should you have any questions about the kit, please contact your local motorcycle dealer.

Please note that, in some cases, the illustrations and photos may vary from the actual hardware.

Read all instructions first before starting the installation

We do not take any responsibility for any accident or damage whatsoever arising from the use of the kit not in conformity with the instructions in the manual.

We shall be held free from any kind of warranty whatsoever of products other than this product if the glitch takes place on the other products than this one after the installation and use of this product.

You are kindly requested not to contact us about the combination of our products with other manufacturers'.

Please note that this kit cannot be attached to a normal or up-type muffler.

The installation procedure for each hose is prepared on the premise of your riding the motorcycle on the public roads. When riding for closed course competition purposes or the like, take every step to meet various regulations.



CAUTION

The following show the envisioned possibility of injuries to human bodies and property damage as a result of disregarding the following cautions.

- Work only when the engine and muffler are cool. (Otherwise, you will get burned.)
- Do the installation with right tools. (Otherwise, breakage of parts or injuries to you may take place.)
- Always use a torque wrench to screw bolts and nuts tight and securely to the specified torque.
(Otherwise, these parts may get damaged or fall off, resulting in accidents.)
- As some products and frames have sharp edges or protruding portions, please work with your hands protected.
(Otherwise, you will suffer injuries.)
- Before riding, always check every hardware for slack in parts like screws. If you find slack ones, screw them securely up to the specified torque.
(Otherwise, improper tightening may cause parts to come off.)
- Use the catch tank with the hose connected at all times. If the tank alone is installed, the stay may get damaged from the jolt, leading to the fall of the tank.



WARNING

The following show the envisioned possibility of human death or serious injuries to human bodies as a result of disregarding the following warnings.

- When you notice something abnormal with your motorcycle while riding, immediately stop riding and park your motorcycle in a safe place to check what has gone wrong. (Otherwise, the abnormality could lead to accidents.)
- Before doing work, make sure your motorcycle is secure on level ground for safety's sake.
(Otherwise, your motorcycle could overturn and injure you while you are working.)
- If you find damaged parts when checking and performing maintenance of your motorcycle, do not use these parts any longer, and replace them with new ones. (The continued use of these damaged parts as they are could lead to accidents.)

Please be informed that, mainly because of improvement in performance, design changes, and cost increase, the product specifications and prices are subject to change without prior notice.

This manual should be retained for future reference.

~ Kit Contents ~

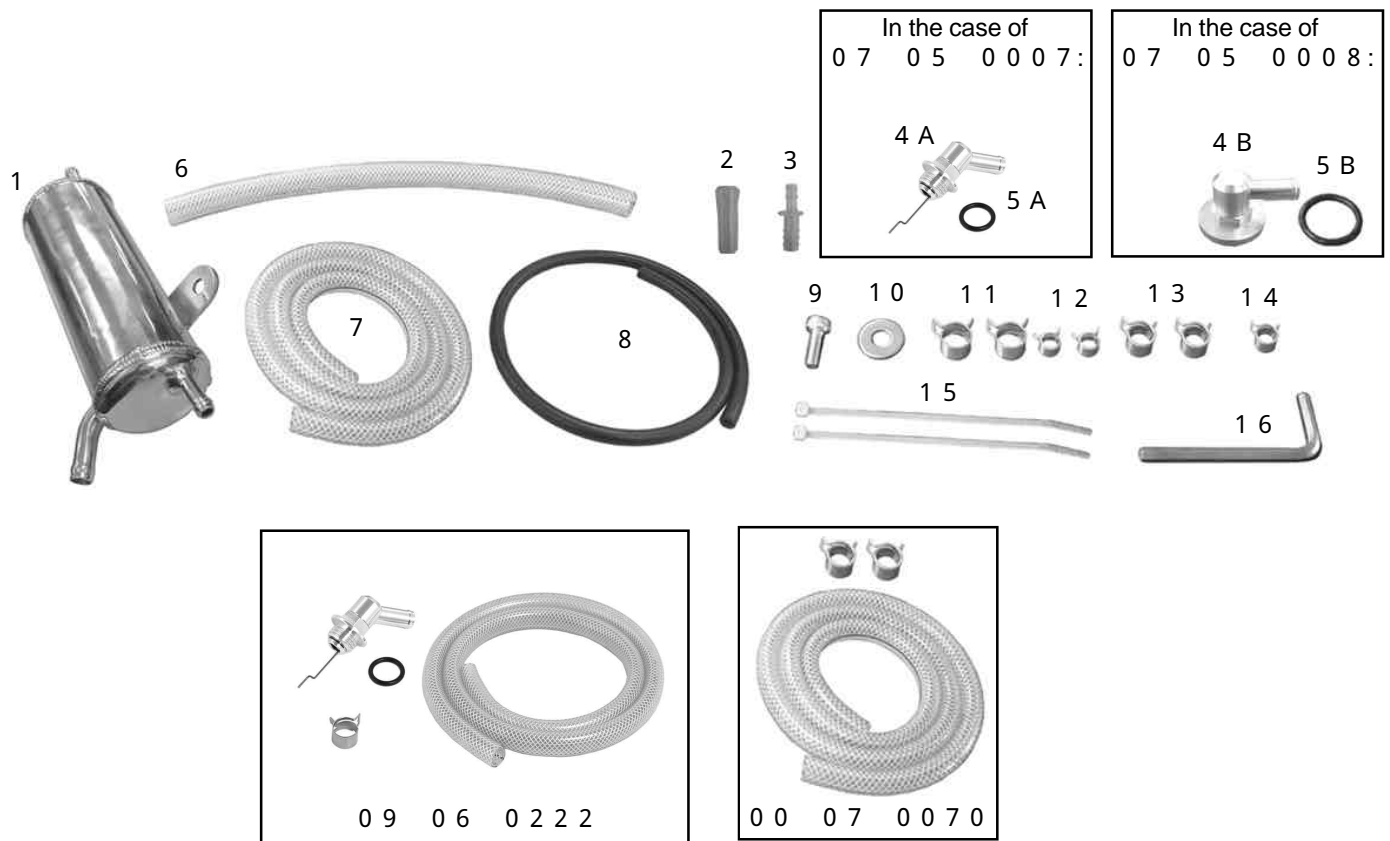

No.	Part Name	Qty	Repair Part Item No.	In the units of
1	Catch tank COMP.	1	07-05-0009	1
2	Masking cap	1	00-00-0219	1
3	Connector	1	00-00-0220	1
4A	Breather cap (For standard clutch)		09-06-0222	1SET
4B	Breather cap (For special or dry-type clutch)	1	07-06-0001	1SET
5A	O-ring, 18 mm		00-00-0093	2
5B	O-ring, 30 mm	1	00-01-0034	4
6	Braid hose, 12 x 500	1	00-07-0069 (1m)	1
7	Braid hose, 8 x 1000	1	00-07-0070 (1m)	1SET
8	Tube, 5 x 1000	1	00-00-0225 (1m)	1
9	Socket cap screw, 8 x 20	1	00-00-0117	4
10	Plain washer, 8 mm	1	00-00-0076	10
11	Hose clamp, 15.5	2	00-00-0215	4
12	Hose clamp, 9.5	2	00-00-0216	4
13	Hose clamp, 13.1	2	00-00-0087	4
14	Hose clamp, 11.6	1	00-00-0221	2
15	Insulation lock, 150 mm	2	00-00-0222	10
16	Hex wrench, 6 mm	1		

Please note that in ordering repair parts, be sure to quote the Repair Part Item No.

Otherwise, we may not be able to accept your orders.

There are some parts, however, for which we are not in a position to accept your order in just the quantity to be used. In this case, please take them in the quantity packed.

~ Installation Instructions ~

For the installation, please refer to the photos.

- 1 . Install the oil-catch tank onto a stock muffler-mounting spot.
- 2 . **Item No. of 07-05-0007: In the case of a vehicles with a stock clutch:**

Detach a oil level gauge from the clutch cover.
Apply engine oil slightly to the O-ring, and install the oil cap.
Torque: 10 N·m (1.0 kgf·m)



Item No. of 07-05-0008: In the case of a special- or dry-type-clutch motorcycle:

Detach an oil filler cap. Apply a thin coat of engine oil to a 30mm O-ring, and attach a breather cap COMP.
Torque: 10 N·m (1.0 kgf·m)



- 3 . Connect the hose to the union, referring to the photo below. Bring a hose on the air-cleaner side toward a rear carrier and connect it. As a hose to be routed is going to be long, it is advisable for you to hold the hose with a insulation lock at some points of the hose. The installation procedure is prepared on the premise of your riding the motorcycle on the public roads. When riding for closed course competition purposes or the like, take every step to meet various regulations.

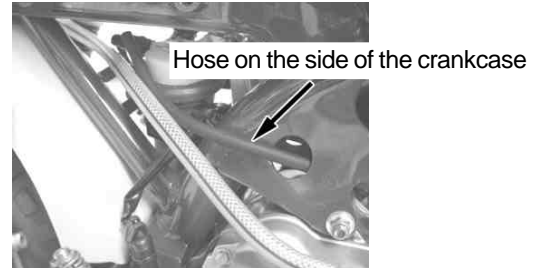
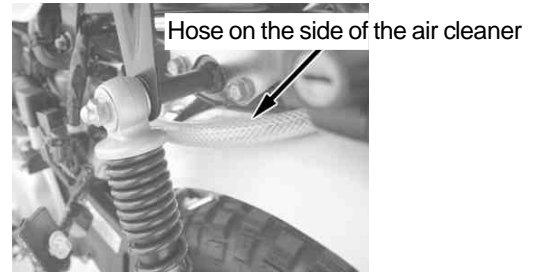
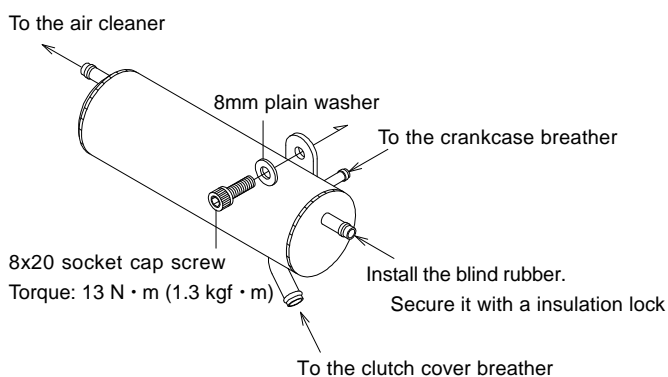

·When installing the oil catch tank onto the crankcase breather, cut the thicker portion, or the air-cleaner-mounting portion, on the genuine breather hose. And attach the included connector and connect the just-cut breather hose and the genuine breather hose, which please secure with a hose clamp (11.6 of the genuine breather hose, and 9.5 of the kit-included hose).

~ Checking of Engine Oil Level (In the case of 07-05-0007) ~

- 1 . Keep the engine idling for a few minutes on level ground.
- 2 . Remove the crank breather cap in a few minutes after turning off the engine. Right after turning off the engine, be careful not to touch the engine itself, muffler and exhaust pipe which are hot enough. Otherwise, you can be burned.
- 3 . Wipe off the oil adhering to the level gauge with a cloth.
- 4 . Place the motorcycle upright, and fit in the crank breather cap. Never press it in. Make sure that the oil level is between upper level and lower level marks on the level gauge.

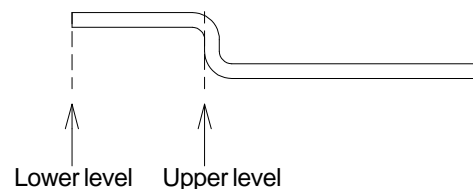

- 5 . If the oil level is close to the lower level mark, add the oil full to the upper level mark through the injection hole. In adding the oil, please be careful not to get the dust in the tank through the oil injection hole. Wipe up spilled gasoline immediately and thoroughly.
- 6 . Fit the crank breather cap securely.

SPECIAL PARTS TAKEGAWA Co.,Ltd.
3-5-16 Nishikiorihigashi Tondabayashi Osaka Japan
TEL: 81-721-25-1357 FAX: 81-721-24-5059 URL: <http://www.takegawa.co.jp>